



## Datasheet

### Draw-wire system SZG165

[www.wachendorff-automation.com/szg165](http://www.wachendorff-automation.com/szg165)

#### Wachendorff Automation

##### ... systems and encoders

- Complete systems
- Industrial rugged encoders to suit your application
- Standard range and customer versions
- Maximum permissible loads
- 48-hour express production
- Made in Germany
- Worldwide distributor network

## Rugged draw-wire system SZG165



- Ball bearing drill protection
- Measuring rope (stainless steel)
- Bushing
- Quick and easy mounting

[www.wachendorff-automation.com/szg165](http://www.wachendorff-automation.com/szg165)

Customs tariff number: 90318020  
Country of origin: Germany

Illustration similar

Mechanical Data				
Measurement range [m]	Extraction force		Speed $V_{max}$ [m/s]	Acceleration $a_{max}$ [m/s <sup>2</sup> ]
	$F_{min}$ [N]	$F_{max}$ [N]		
8	8.2	15.2	8	120
10	4.8	7.2	6	80
20	6.4	9.2	5	60
40	5.4	9	5	60

Technical data SZG165					
Measurement range	[m]	8	10	20	40
Linearity	[%]	0.05 (encoder output)			
Disc circumference	[mm]	357.14	333.33		
Temperature range	[°C]	-20 °C up to +85 °C (observe max. encoder temperature)			
Weight	[g]	3200 to 5000, depending on the measurement range			
Housing		aluminium, anodised, spring case PA6			
Encoder requirements		Shaft: Ø 10 mm, clamping flange: Ø 36 mm, shaft length: 20 mm			
Order No.: without encoder		SZG1650800UZVK	SZG1651000UZVK	SZG1652000UZVK	SZG1654000UZVK

Example Order No.: incremental					
Type	Wire length	Pulses	Channels	Output circuit	Connection
SZG165	0800	02500	AB	R24	SB8

Example Order No.: absolute									
Type	Wire length	Single-turn	Multi-turn	Interface	Software	Code	Power supply	galv. isolation	Connection
SZG165	0800	12	18	CO	A	B	0	0	CB5

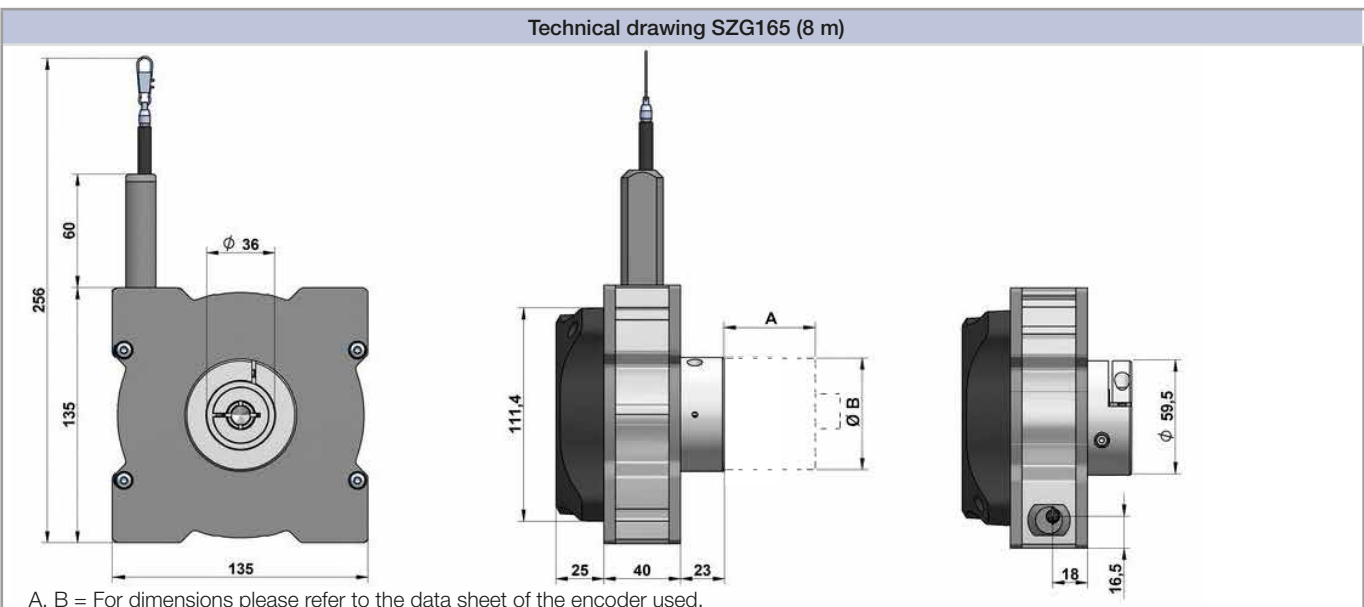

Technical drawing SZG165 (10 m)

position of rope outlet	10 m
start of meas. range (X*)	33
end of meas. range (X**)	18

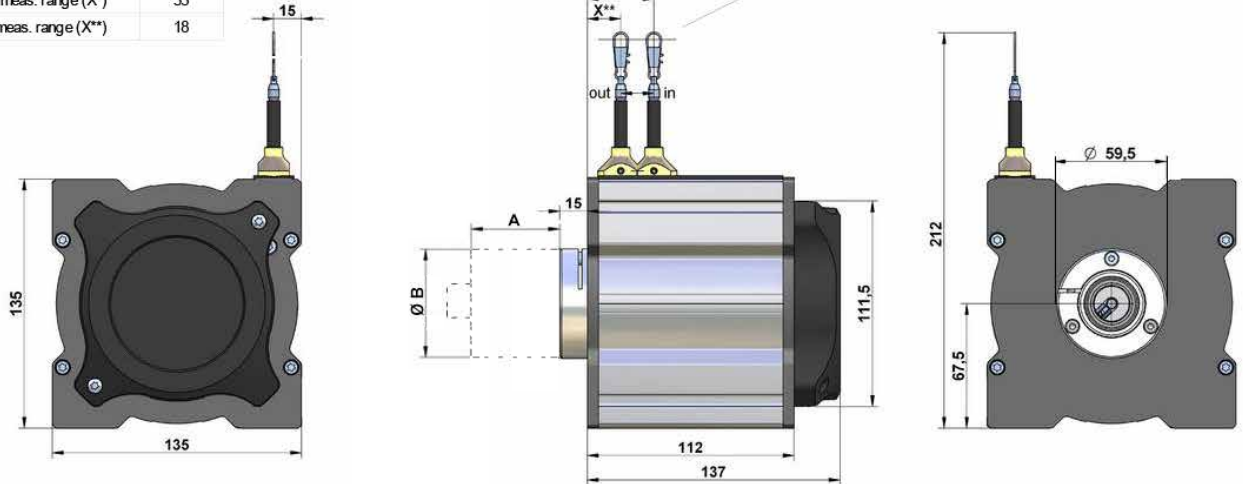

A, B = For dimensions please refer to the data sheet of the encoder used.

Technical drawing SZG165 (20 m)

position of rope outlet	20 m
start of meas. range (X*)	48
end of meas. range (X**)	18

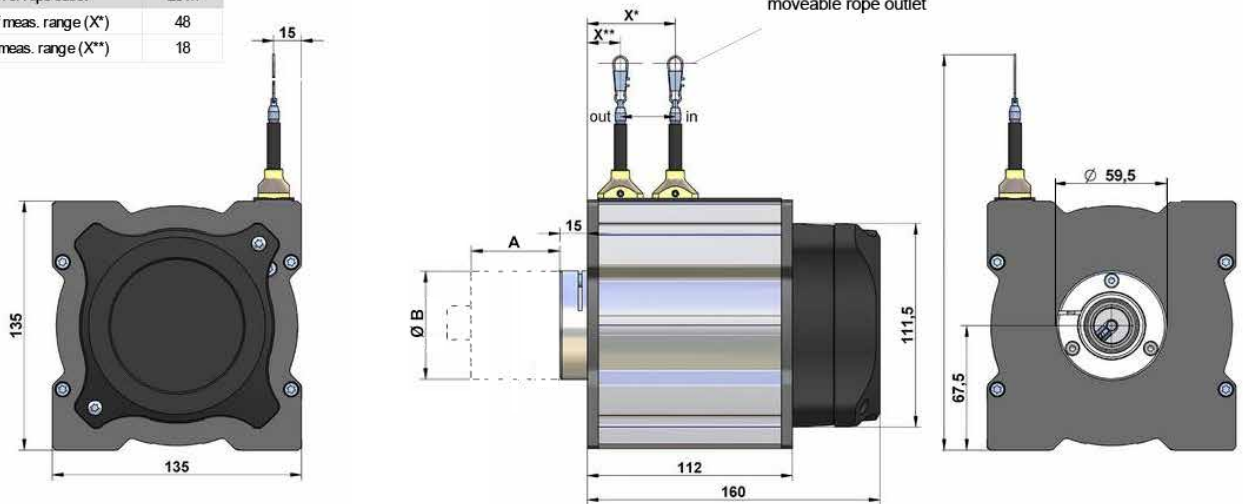

A, B = For dimensions please refer to the data sheet of the encoder used.



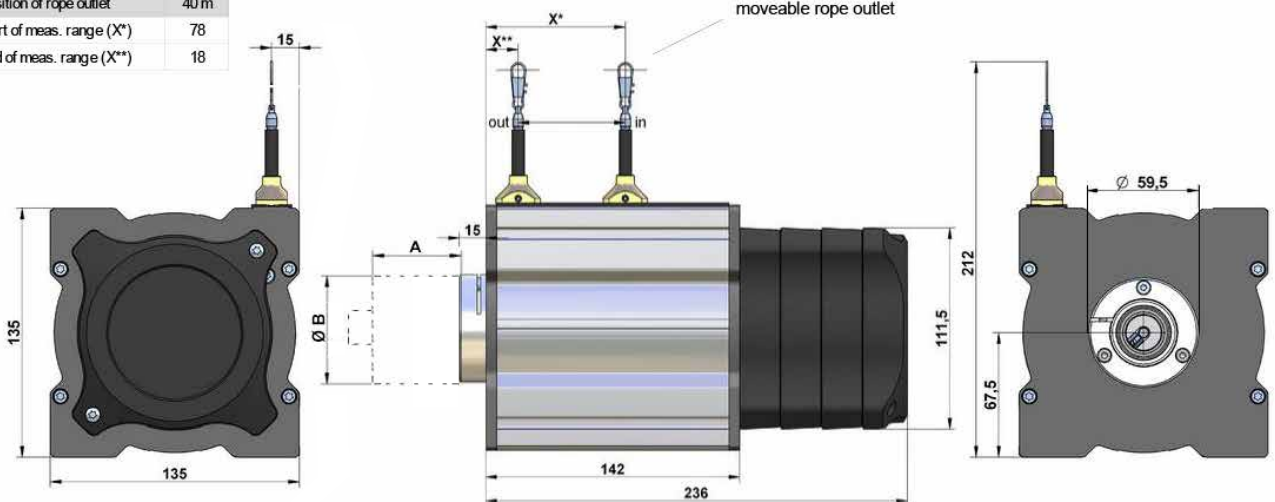

Technical drawing SZG165 (40 m)

position of rope outlet	40 m
start of meas. range (X*)	78
end of meas. range (X**)	18



A, B = For dimensions please refer to the data sheet of the encoder used.

**SZG165 Encoder mounting (8 m)**

	<p><b>1.</b></p> <p>Please insert the encoder into the clamping flange.</p>		<p><b>2.</b></p> <p>The encoder is now connected to the clamping flange.</p>
	<p><b>3.</b></p> <p>By tightening (approx. 2 Nm) the inner radial screw with a 2.5 mm hex wrench the encoder shaft will be clamped to the sensor mechanics and secured from twisting.</p>		<p><b>4.</b></p> <p>By tightening (approx. 2 Nm) the outer radial screw with a 2.5 mm hex wrench the encoder housing will be clamped to the sensor housing and secured from twisting. The system is now ready to be used.</p>

**SZG165 Encoder mounting (10 m up to 40 m)**

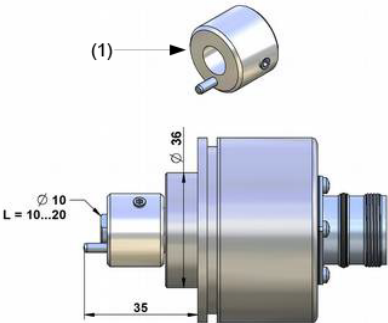
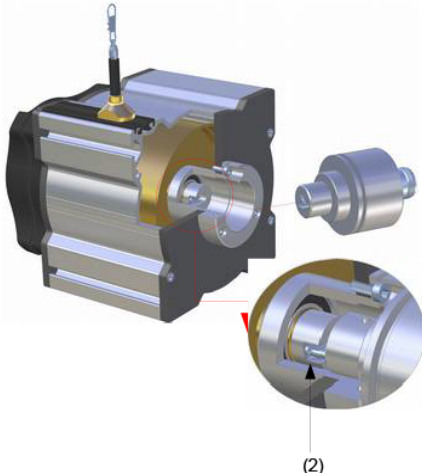
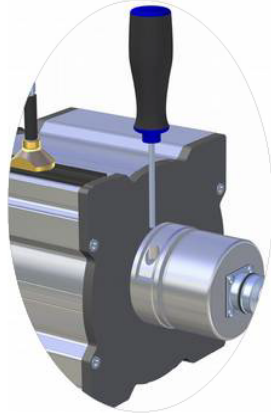
<p><b>1.</b></p> <p>Please mount the included coupling (1) on the shaft of the encoder and fix the set screw (1.0 Nm). Therefore you will need a hexagon screwdriver, size 2. Please pay attention that the dimension between contact surface of the encoder and the end of the cylinder bolt is <u>35 mm</u>.</p> 	<p><b>2.</b></p> <p>Please mount the encoder into the easy-clamp-flange. The cylinder bolt must slip into the spring (2).</p> 	<p><b>3.</b></p> <p>By tightening (1.5 Nm) the radial screw the encoder will be clamped and secured from twisting. Please use a hexagon screwdriver, size 3.</p> 
--	---	--

Note: All incremental WDG158B or absolute WDGA58B encoders are suitable for mounting.

## Installation

- Mount the sensor at the designated place, before extracting the rope and before attaching the rope to the measuring target.
- The sensor can be installed in two ways, by using the supplied T-slot nuts, or the clamp brackets. You will find a detailed description of both installation methods in the next section.
- Open the rope clip after the sensor is fully mounted and extract the measuring rope. Hook the rope clip on the measuring object and close the bracket of the clip. For safety reasons put a screw driver trough the clip to extract the rope.
- Check the track of the measuring target on collision with the sensor housing and on exceeding the specified measurement range. When installing the sensor make sure that the rubber stopper does not touch the rope outlet.
- Connect the electronics according to the sensor type. When laying the cables be careful not to under-run the minimal allowed bending radius of the cable (5 x cable diameter).
- The rope must be extracted from the sensor vertically. The maximum variation from the vertical is 3°. Avoid carefully extracting the rope at an inclination, since the durability of the instrument would shorten considerably. If it is not possible to keep the limit of 3°, a deflection pulley has to be used.
- The measuring range begins after approximately 2 mm extracted rope (=zero point). The mechanical reserve at the end of the measuring range is about 20 mm.
- When mounting outdoors protect the sensor and the rope from icing at temperatures below 0 °C.
- Guide the rope preferably in corners or guarded in channels to prevent pollution or accidental touch.
- When operating the sensor, take care not to let the rope snap back by mistake or extract the rope over the specified measurement range, as this might destroy the sensor.
- Maintenance: These instruments are maintenance-free. If however, the rope is soiled due to adverse environmental conditions, it can be cleaned with a cloth drenched in resin-free machine oil.

## Mounting

### 1. Mounting via T-slot nuts

The included T-slot nuts can be easily inserted into the grooves of the sensor housing. The nuts have a metric thread M6. Two (up to 20 m measurement range) or four (more than 25 m measurement range) T-slot nuts are included in the delivery.

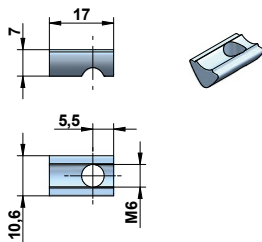

### 2. Mounting via angle clamp brackets

The angle clamp brackets feature a bore for M6 screws to fix it on a plate, slab or a profile. Two (up to 20 m measurement range) or four (more than 25 m measurement range) angle clamp brackets are included in the delivery.

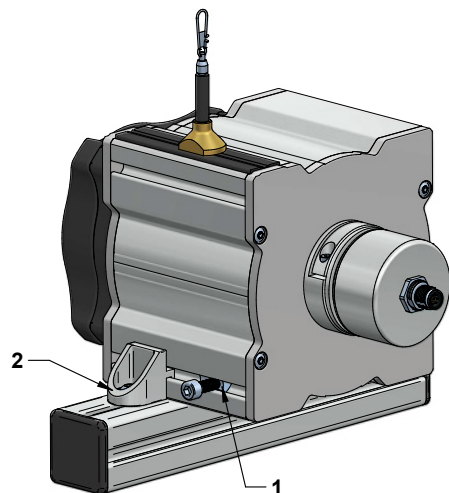
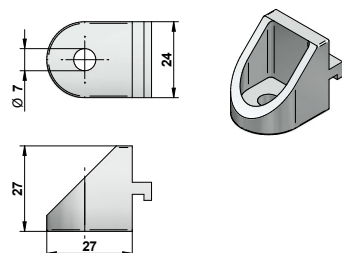



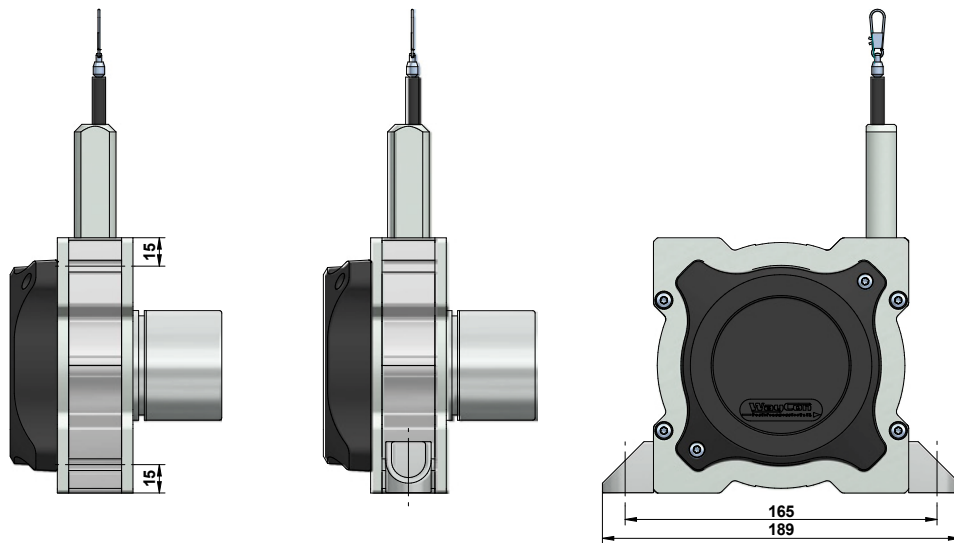







**Position of the grooves and angle clamp brackets**



**WARNING NOTICES**

- Don't let the rope snap back. If the rope is retracted freely, this may lead to injuries (whiplash effect) and the device may be damaged. Caution when unhooking and retracting the rope into the sensor.
- Never exceed the specified measurement range when extracting the rope!
- Do not touch the rope when operating the sensor.
- Avoid guiding the rope over edges or corners. Use a deflection pulley instead.
- Do not operate the sensor if the rope is buckled or damaged. A ripping of the rope may lead to injuries or a damaging of the sensor.
- Do not oil or grease the entire wire pull system.
- Do not pull the measuring wire at an angle.
- Attach the measuring cable retracted to the object to be measured.
- Do not try to open the device. The stored energy of the spring drive may lead to injuries when being mishandled.
- A tensioned measuring cable can lead to injuries in the area where operating personnel are present.
- Do not damage the measuring wire.
- Draw-wire displacement sensors are used for displacement and displacement measurement or position detection of components or moving machine components.
- The sensor may only be operated within the values specified in the technical data.
- The sensor must be used in such a way that no persons are endangered or machines and other material goods are damaged in the event of malfunction or total failure of the sensor.

<p><b>Montage nur qualifiziertes Personal, Personal, Assembly only qualified personnel, Montage par qualifié personnel, Montaggio solo personale qualificato, Montaje solamente personal cualificado.</b></p> <p><b>Sicherheitsmassnahmen/Safety instructions:</b> Einsatz nur in Industrieumgebung und NICHT im sicherheitsrelevanten Bereich. Only for use in industrial environments and NOT for safety-relevant areas. Utilisation uniquement dans un environnement industriel et PAS dans un domaine lié à la sécurité. Utilicelo sólo en entornos industriales y NO en áreas relevantes para la seguridad. Utilizzare solo in ambienti industriali e NON in aree riguardanti la sicurezza.</p>	
<p><b>Power supply: Class 2 only</b></p>	<p>   </p> <p>DIN EN 100015 - 1</p>
	<p> </p> <p>   </p>

**WACHENDORFF**  
The Encoder Experts

**Authorized Distributor**

For further information please contact our local distributor.  
Here you find a list of our distributors worldwide.

<https://www.wachendorff-automation.com/distributors-worldwide/>

**WACHENDORFF**

Wachendorff Automation GmbH & Co. KG  
Industriestrasse 7 • D-65366 Geisenheim

Tel.: +49 (0) 67 22 / 99 65 - 25  
Fax: +49 (0) 67 22 / 99 65 - 70  
E-Mail: [wdg@wachendorff.de](mailto:wdg@wachendorff.de)  
[www.wachendorff-automation.com](http://www.wachendorff-automation.com)

